



Scegli la sicurezza



Coniugare Salute e Sicurezza del lavoro e Produttività

Unita' di Ricerca EPM
SESTO SEMINARIO INTERNAZIONALE
Milano

Simone Schiaroli

Our Company

- 
- ✓ **Presenza:** 24 sedi commerciali nel mondo
 - ✓ **Fatturato 2010:** 2,9 Mld €
 - ✓ **Linee di prodotto:** Frigoriferi, lavabiancheria, lavastoviglie, asciugatrici, congelatori, cappe, forni e piani cottura. Free standing, Built In.
 - ✓ **Produzione:** 14 impianti nel mondo
 - ✓ **Dipendenti:** 16.000
 - ✓ **Quotazione:** Presente alla Borsa di Milano dal 1987

Ergonomia e Innovazione

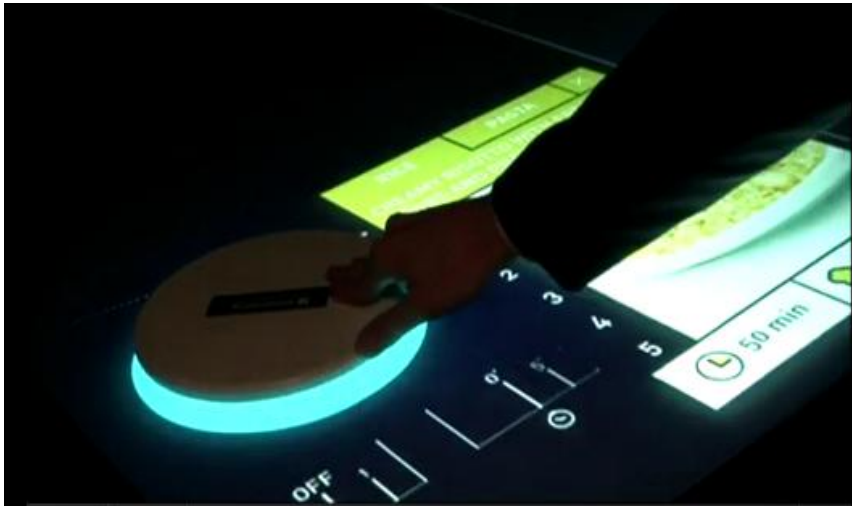
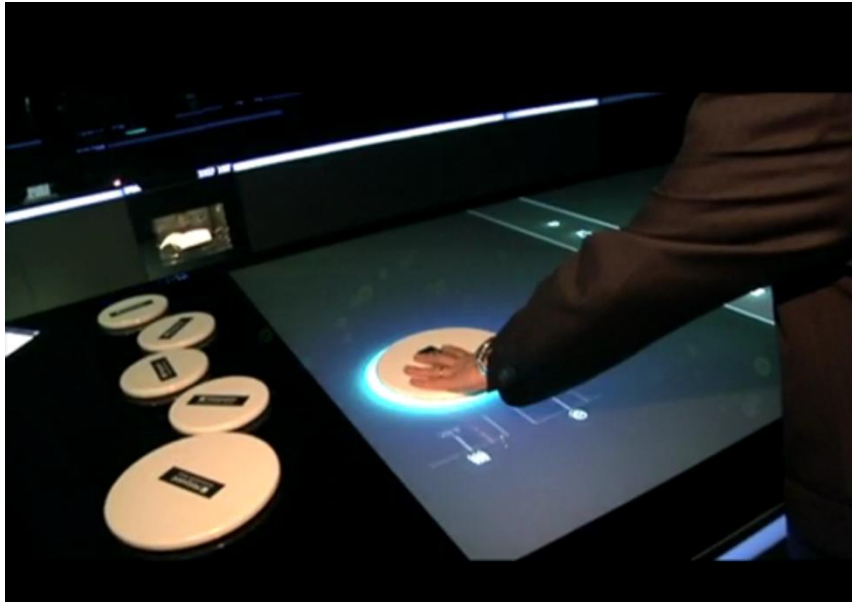

Paesi coinvolti



- ***Persone coinvolte: >95%***
- ***Siti Certificati: 35***
- ***Standard certificazione: OHSAS***
- ***Ente di Certificazione: SGS***



L'andamento dell'indice infortunistico di gruppo

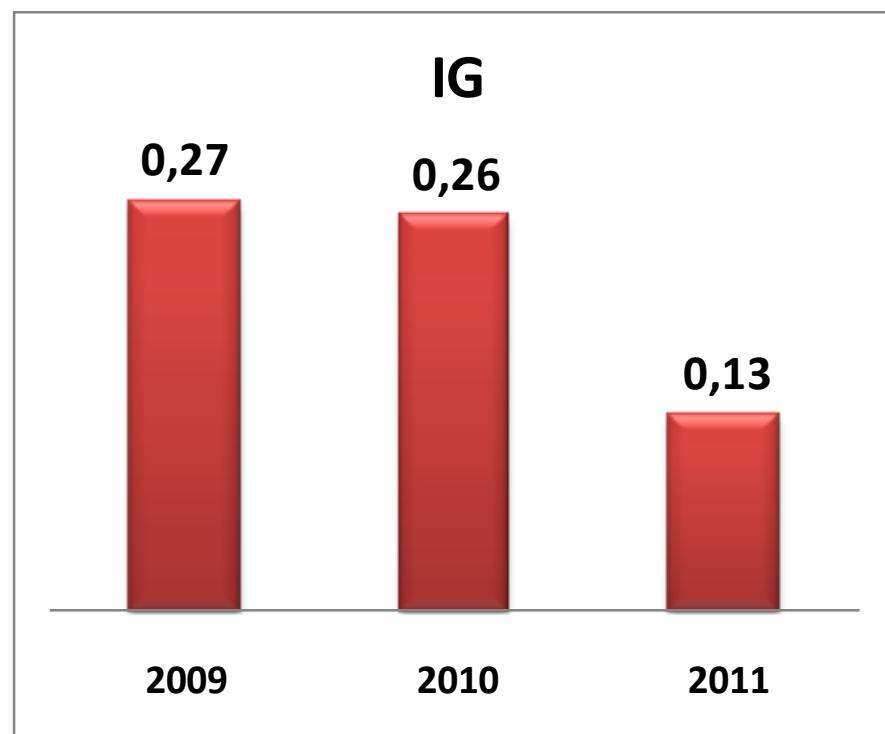
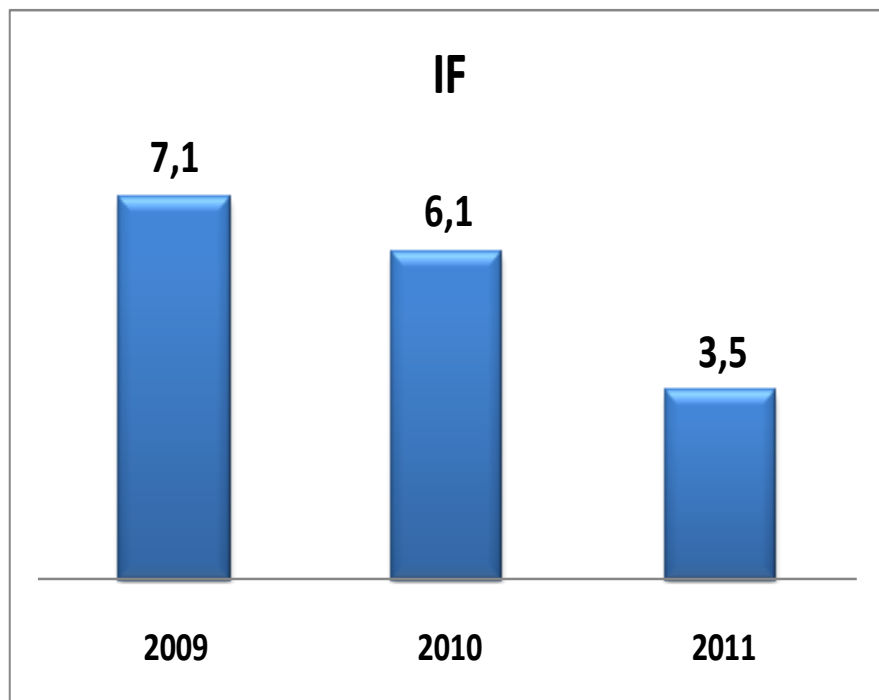

I near miss come strumento di prevenzione dei rischi

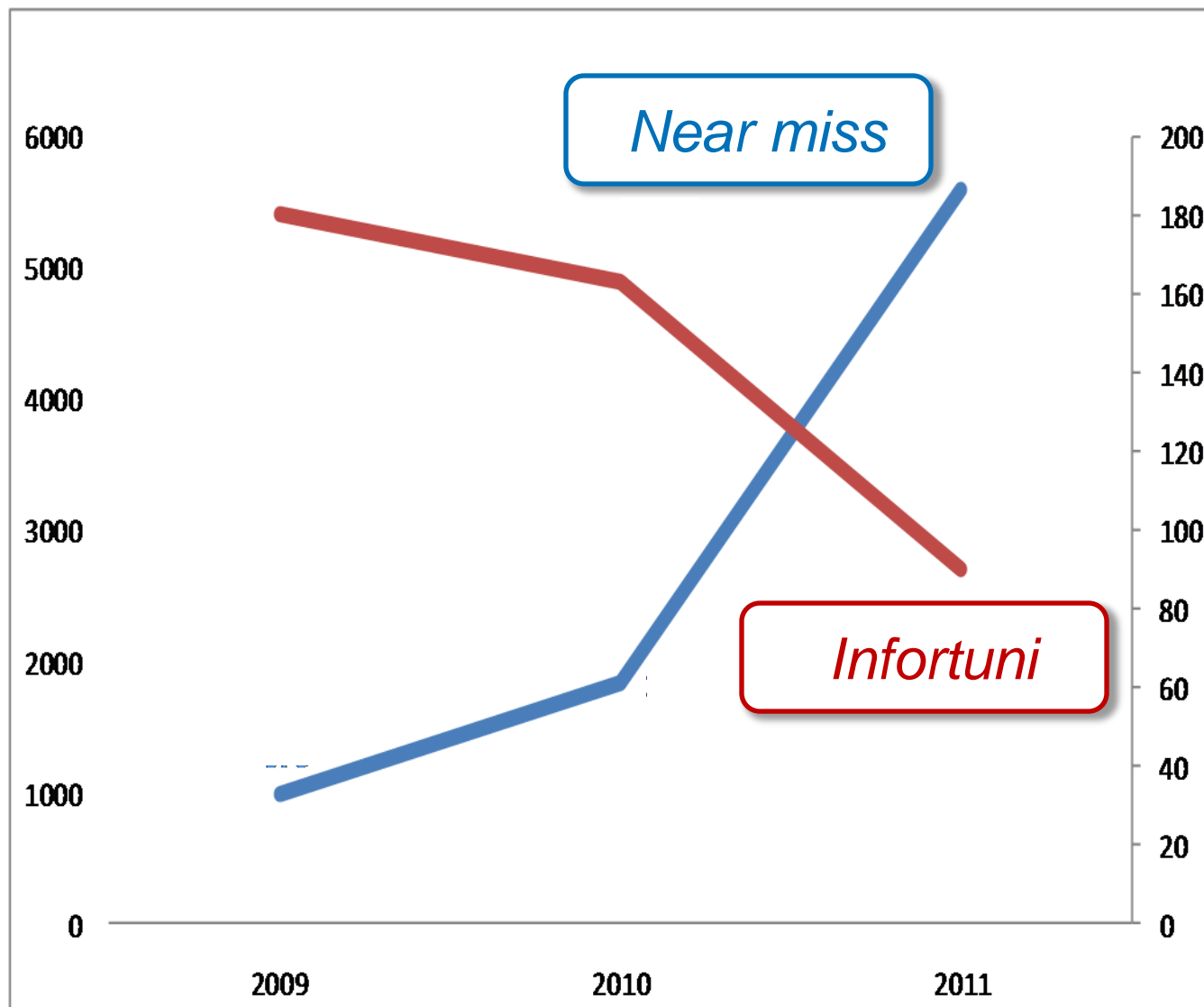

Promozione della sicurezza



INDESIT
company

Nome Surname
Distribuzione Italiana

Safety matters

Make safety your priority



Choose Safety



INDESIT
company

Безопасность имеет значение

Не из каждого правила есть исключение



Выберите безопасность



INDESIT
company

Nome Cognome
Distribuzione Italiana

La sicurezza vale

Usa i dispositivi di sicurezza



Scegli la sicurezza



INDESIT
company

Безопасность имеет значение

НЕ "забывай" на безопасность



Выберите безопасность



INDESIT
company

La sicurezza vale

Mettici attenzione



Scegli la sicurezza

Nome Cognome
Distribuzione Italiana



INDESIT
company

Health and Safety

Choose Safety



INDESIT
company

La sicurezza vale

A casa e sul lavoro



Scegli la sicurezza

Francesca Fumelli
Fiorino Homeage

I progetti rivolti al miglioramento della salute

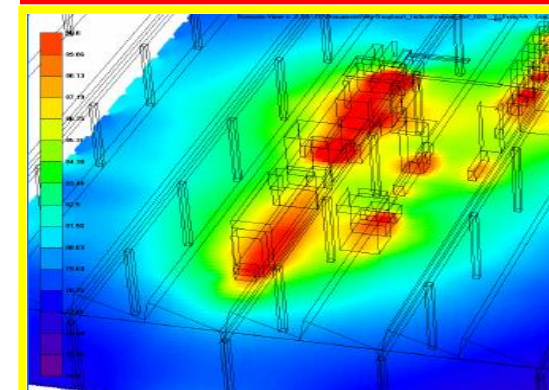
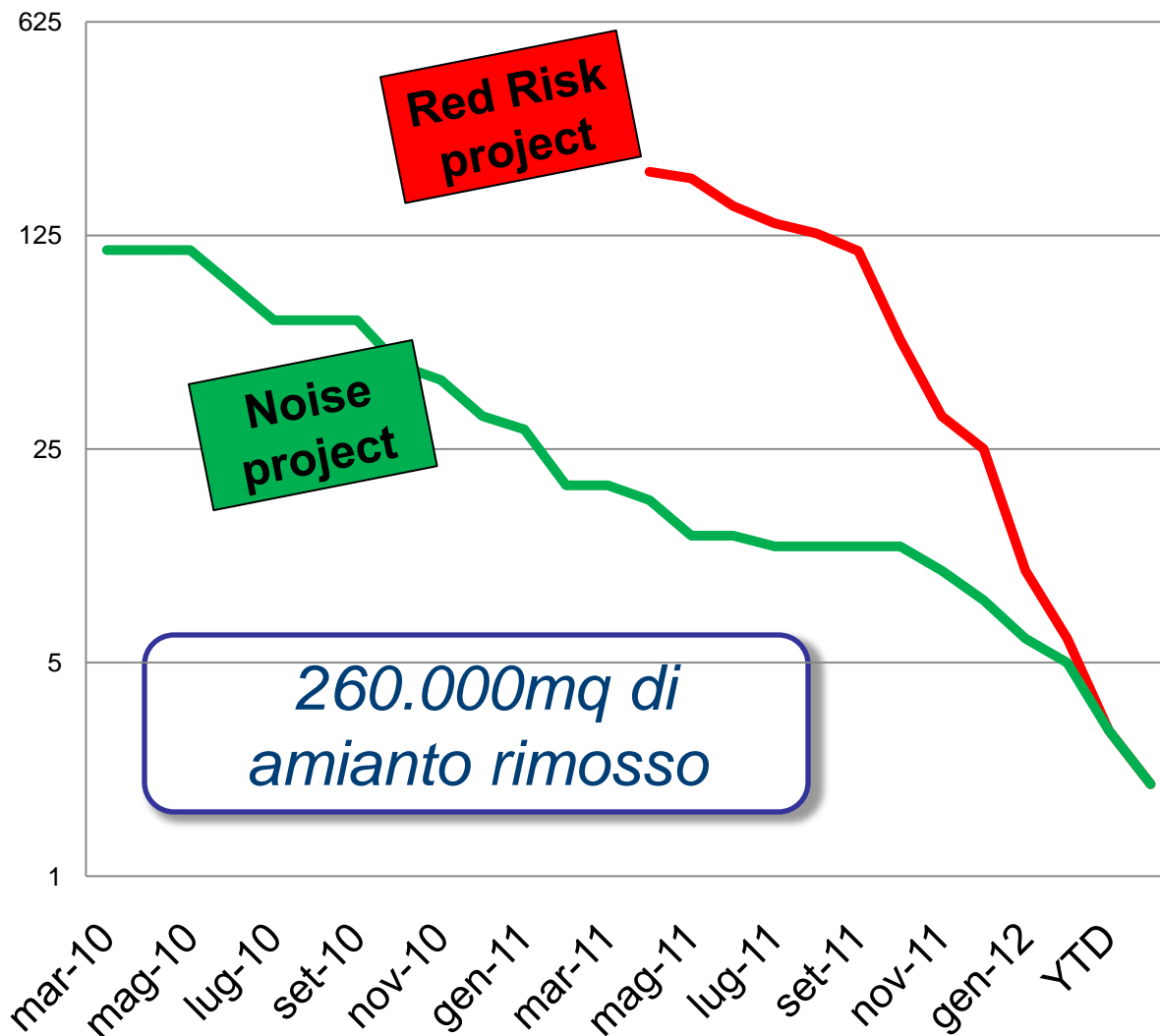

Drivelines

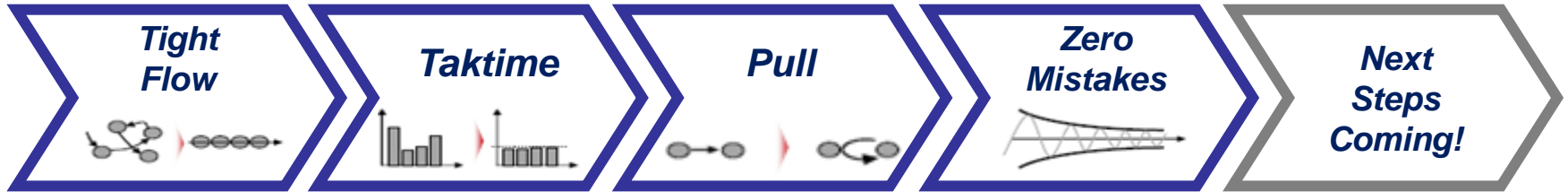

Goals



Improve Quality

Reduce HS risks

Reduce Waste

Reduce Time

Reduce Cost

Workstation organisation has a strong impact on Ergonomic associated Risk



La nostra forza:
lavorare in modo sicuro
ed ergonomico

**Il nostro
obiettivo:**
valorizzare
l'impegno di tutti

La nostra eccellenza:
migliorare continuamente
in qualità, costi e servizio

Il nostro valore:
eliminare
gli sprechi

IME Strike zone

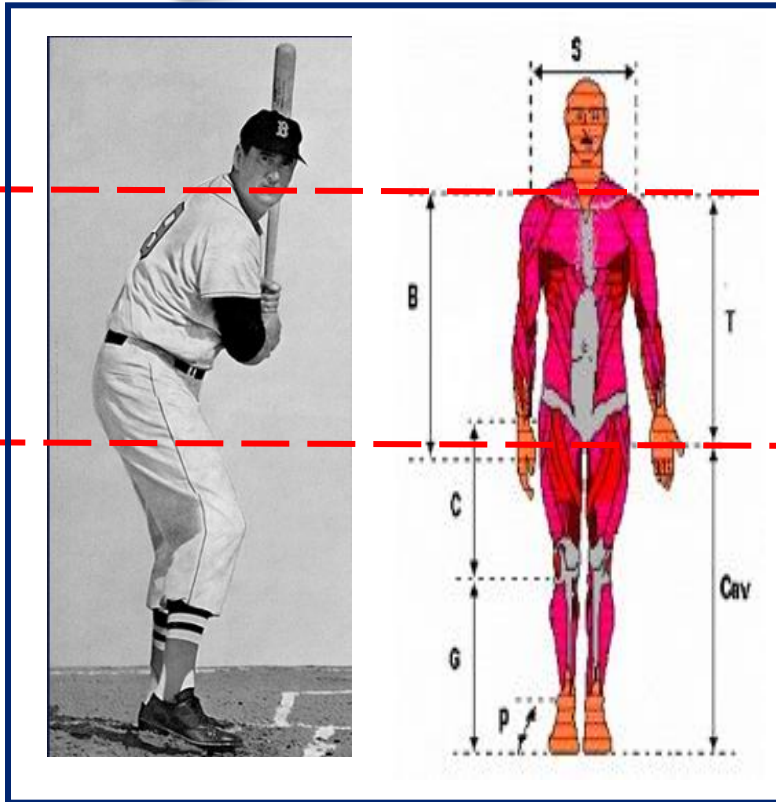

NIOSH Ideal zone

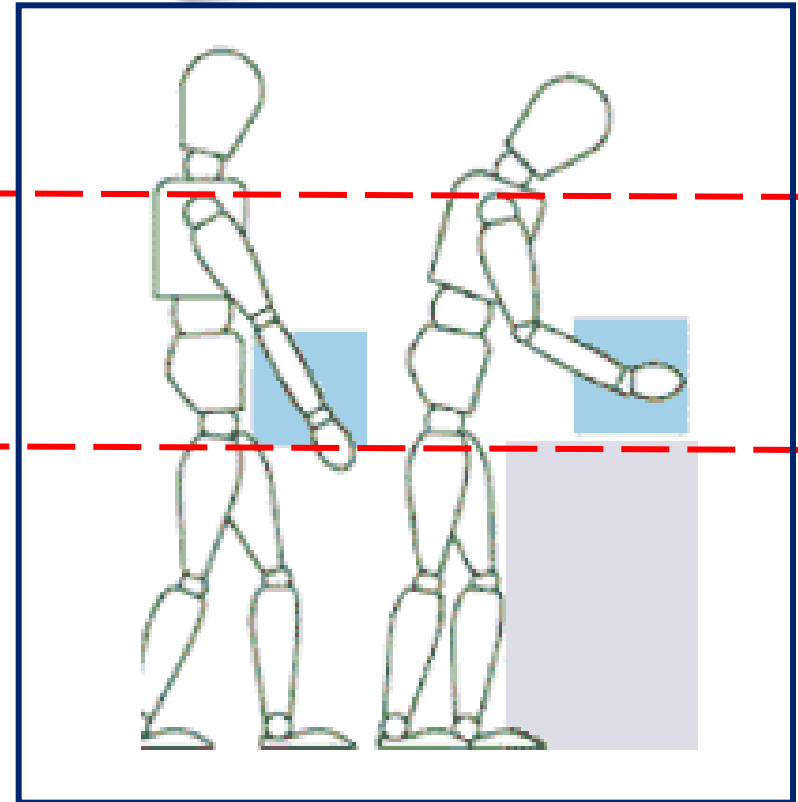

Strike Zone



**IME
Strike zone**

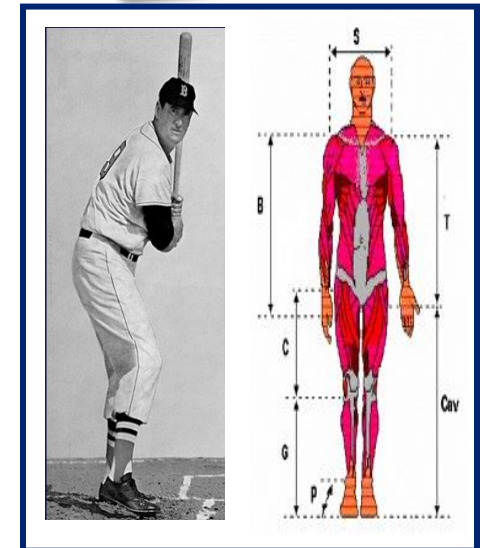

IME Golden zone

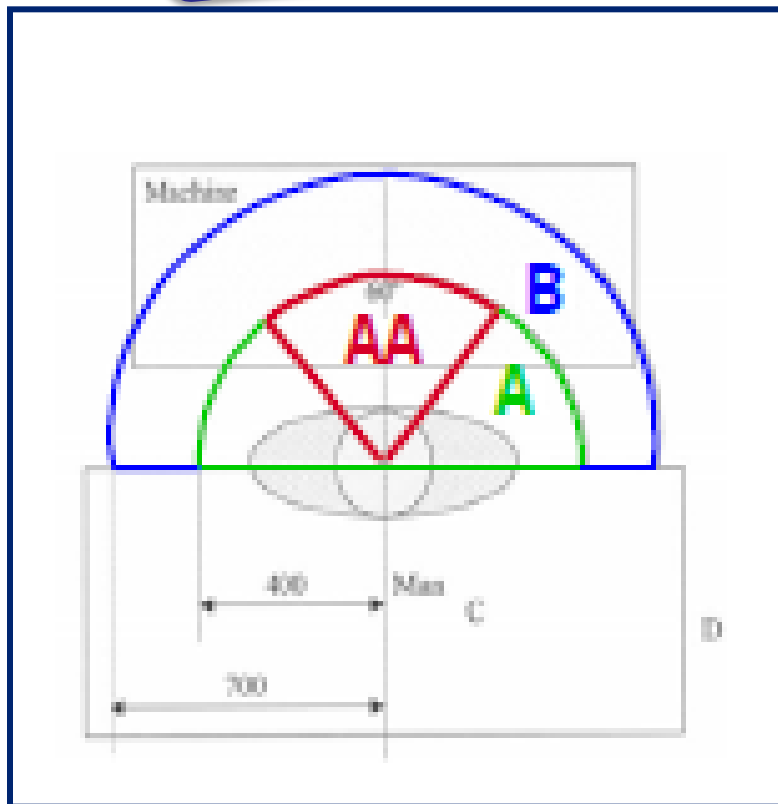

OCRA Ideal zone

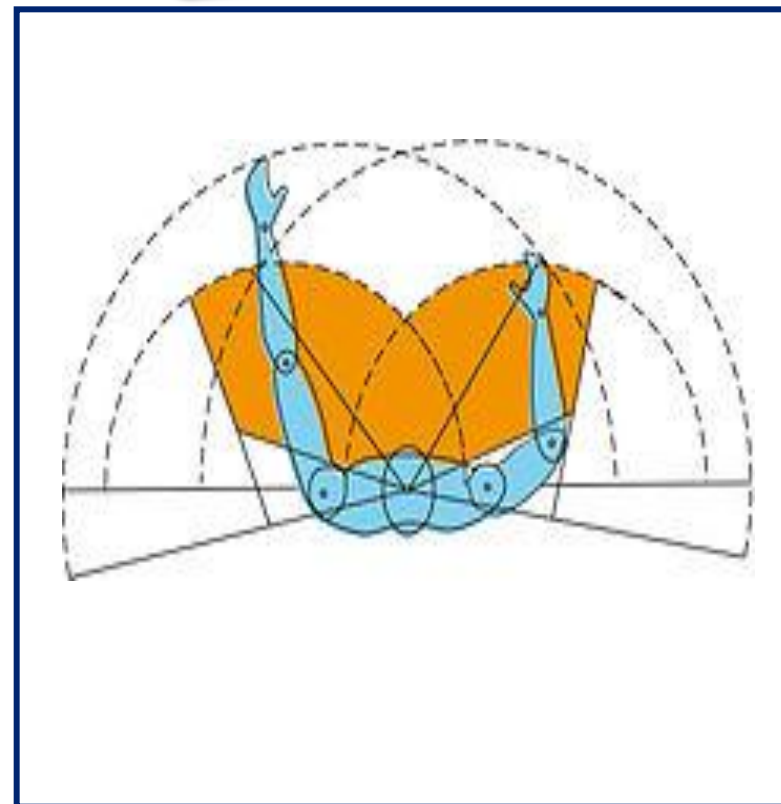

Golden zone Analysis - OCRA

Check list
OCRA

14,5

prima



dopo

Check list
OCRA

7,4



IME
Golden zone

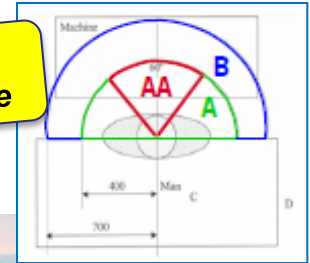

INDI203
LINE 5
GOLDEN ZONE ANALYSIS
07.05.14

| STATION N°. | ZONE AA | ZONE A | ZONE B | ZONE C | ZONE D | HAND & ARM MOVEMENT | STRIKE ZONE |
|-------------|---------|--------|--------|--------|--------|---------------------|-------------|
| 21 | 38% | 25% | 12% | 12% | 12% | 26 | 88% |
| 22 | 40% | 60% | / | / | / | 17 | 100% |
| 23 | 25% | 50% | / | 25% | / | 13 | 100% |
| 24 | 43% | 43% | / | / | 14% | 17 | 100% |
| 25 | 50% | 33% | / | / | 17% | 18 | 100% |
| 26 | 55% | 36% | / | / | 14% | 33 | 91% |
| 27 | 71% | / | / | / | 29% | 22 | 100% |

Manipolatori Industriali



prima

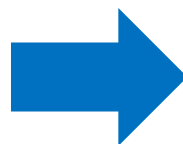

dopo

Indice NIOSH 1,1

Rischio assente

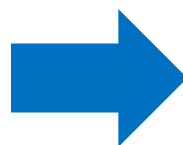

Indice NIOSH 1,24

Rischio assente

Riprogettazione postazione di lavoro - piani cottura



prima



dopo

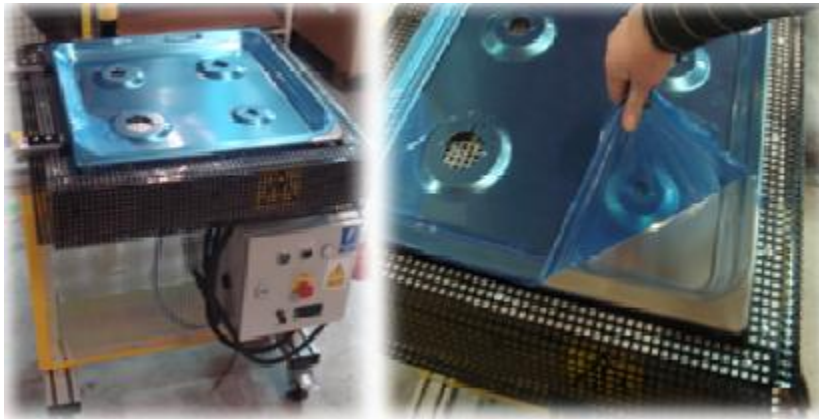
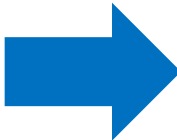

Check list OCRA 14,00

Check list OCRA 5,2

Riprogettazione postazione di lavoro - forni

prima



dopo



Indice NIOSH

1,3

Indice NIOSH

0,6

Riprogettazione postazione di lavoro - lavabiancheria



Check list OCRA

9,12

Indice NIOSH

1,1

**L'operatore alla fine del turno ha percorso una
distanza di circa 3700 metri**

Riprogettazione postazione di lavoro - lavabiancheria

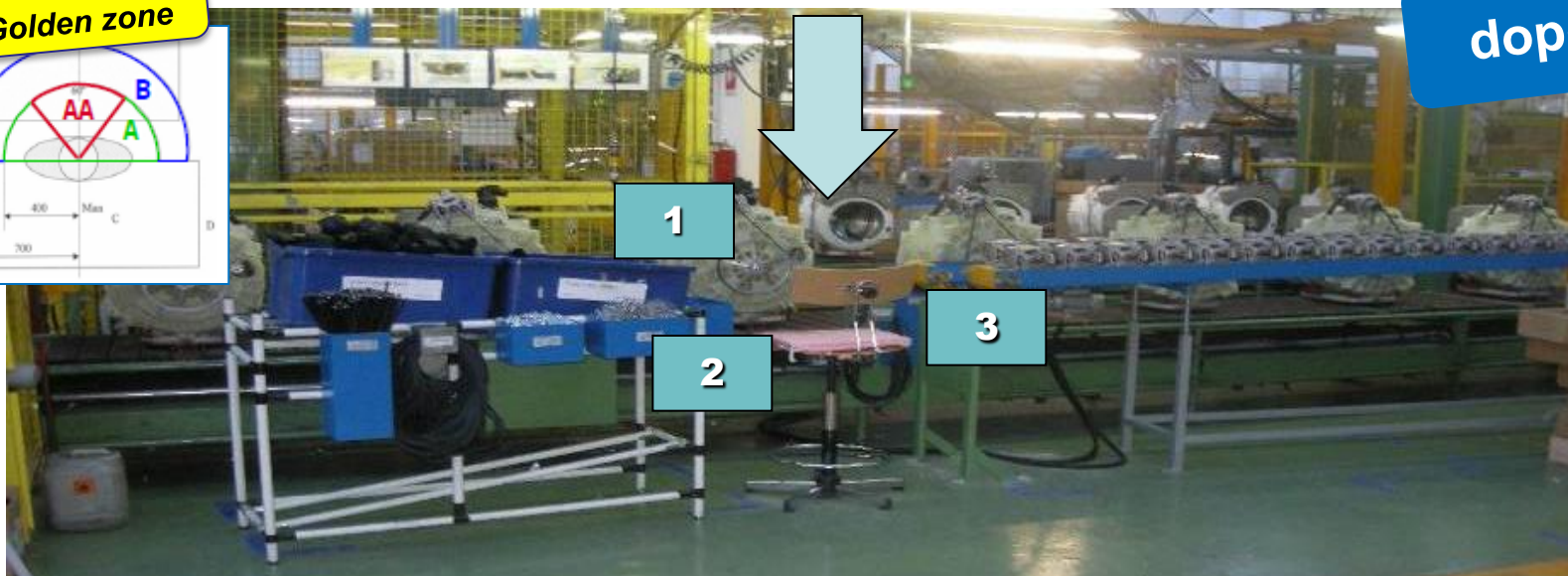
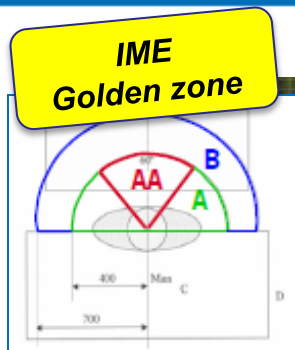

Check list OCRA

7,41

Indice NIOSH

0,5

L'operatore è seduto

Valutazione delle posture e inclinazioni del tronco

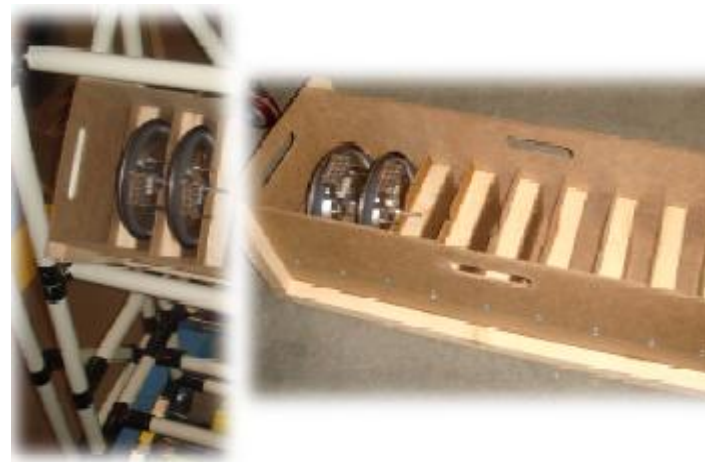
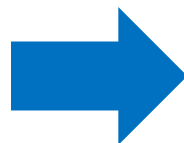
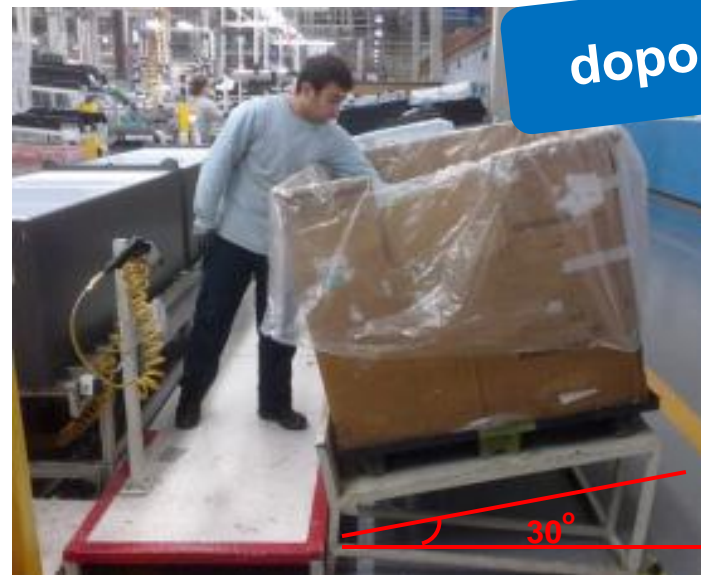
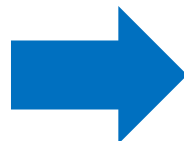

OCRA SYSTEM

Minicheck OCRA

- Valutazione del rischio rapida, screening iniziale, in fase di test

Check list OCRA

- Mappatura del rischio classica e prima gestione del rischio

Indice OCRA

- Valutazione del rischio puntiforme, progettazione e riprogettazione posti di lavoro

Confronto tra OCRA checklist e mini-checklist

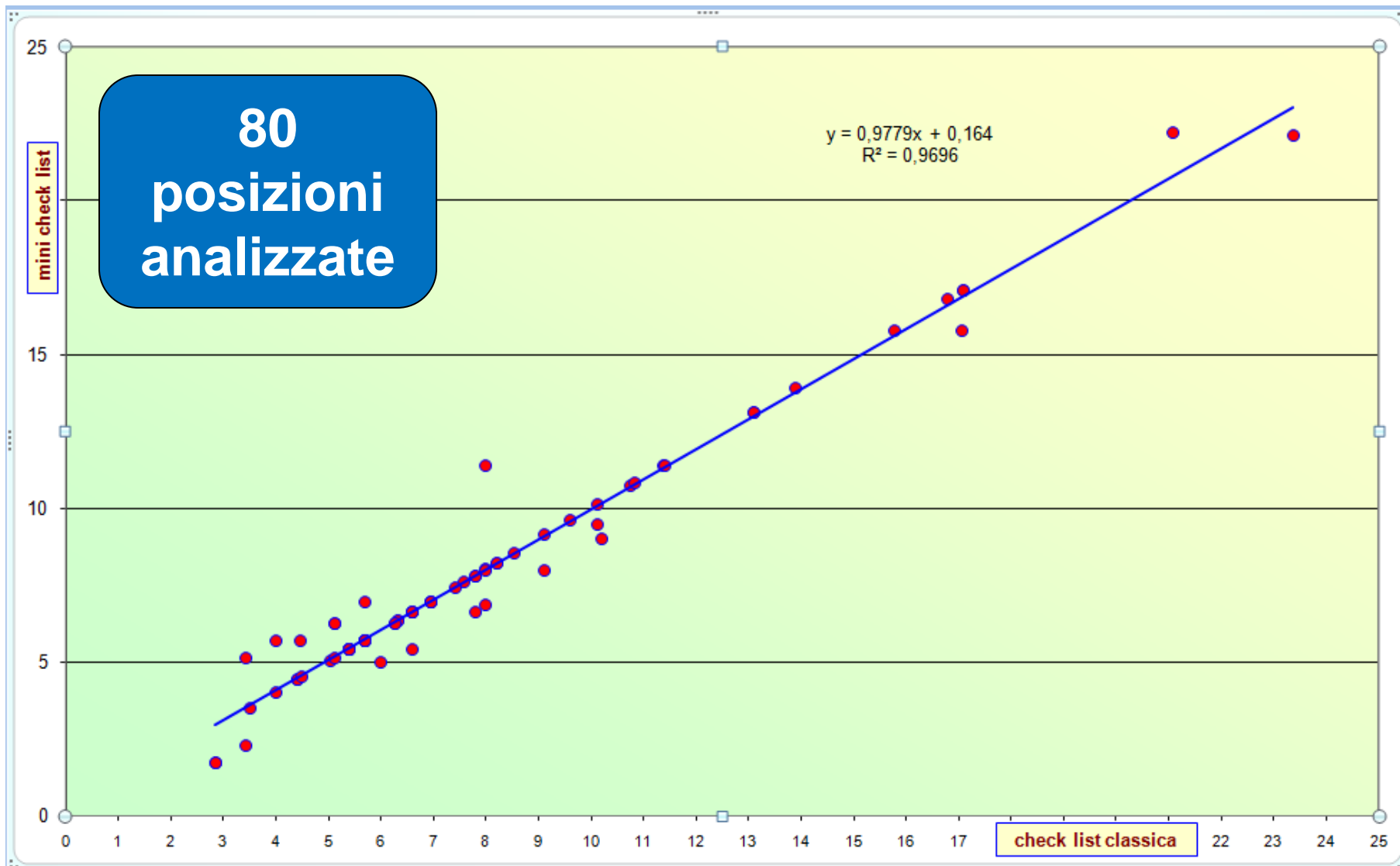

Ergonomia e Produttività

prima



dopo



Produttività
+10/20%

Check list
OCRA
-10/20%



La formazione e l'addestramento delle figure chiave rivestono un ruolo determinante per ottenere risultati eccellenti



Progettazione e realizzazione posizioni prototipo

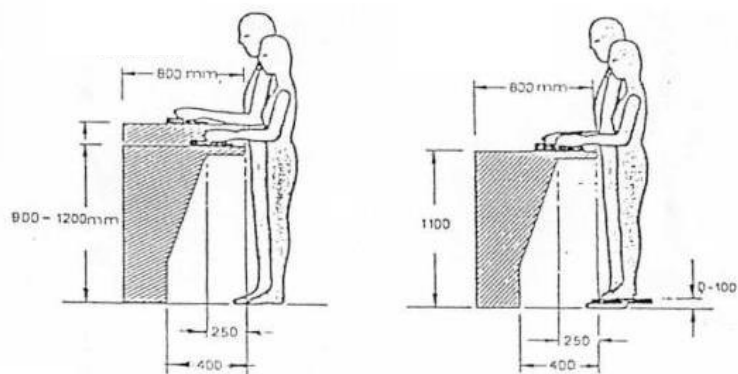
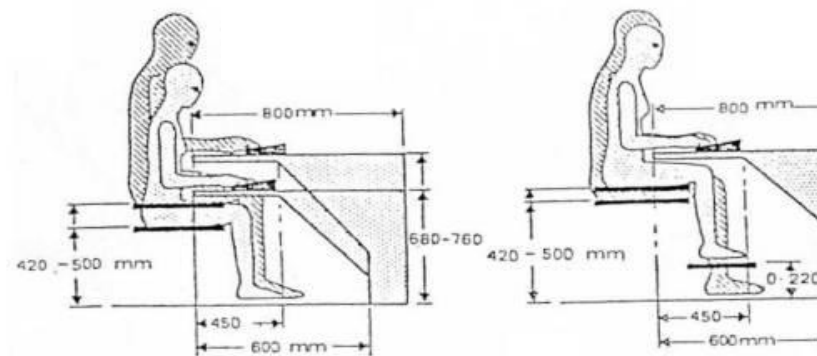

I sistemi optoelettronici



Basati su sistemi di telecamere infrarosse che rilevano degli specifici marcatori e ricostruiscono il movimento in 3 D

Software di modellazione e simulazione umana

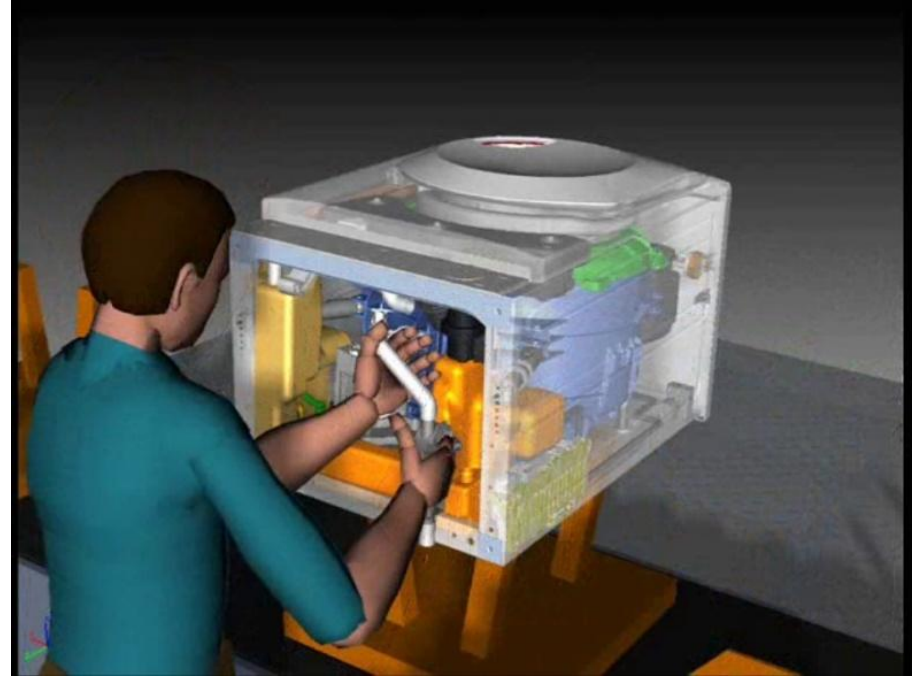
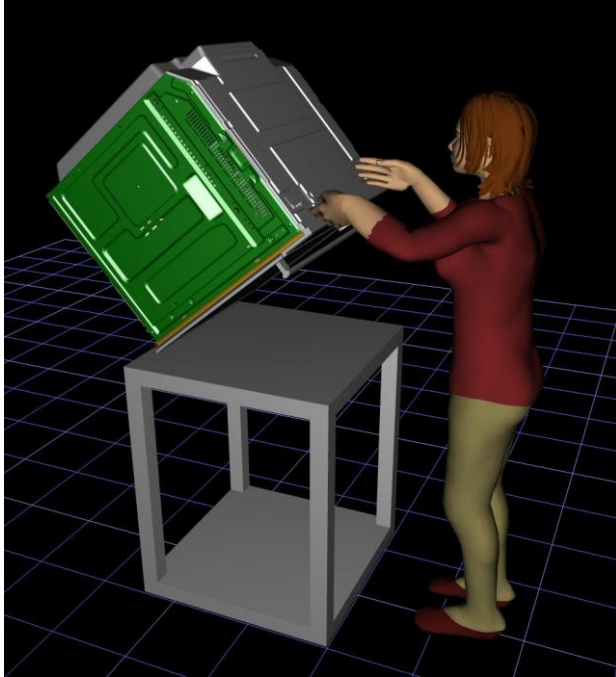

Tramite software dedicati è possibile posizionare biomeccanicamente umanoidi digitali di diverse dimensioni in ambienti virtuali, assegnando loro specifiche mansioni e analizzando le loro prestazioni

Software di gestione integrata del rischio da sovraccarico biomeccanico

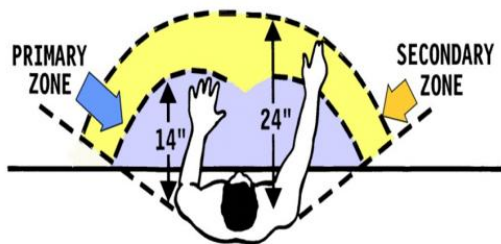

ergonomia



**Tempi e
metodi**

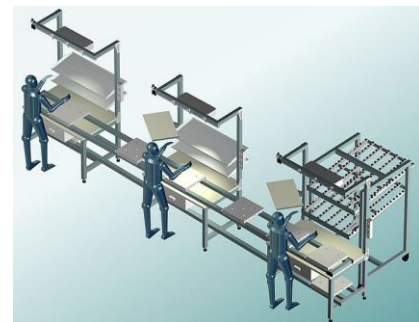

Bilanciamenti



Attrezzature



Materiali

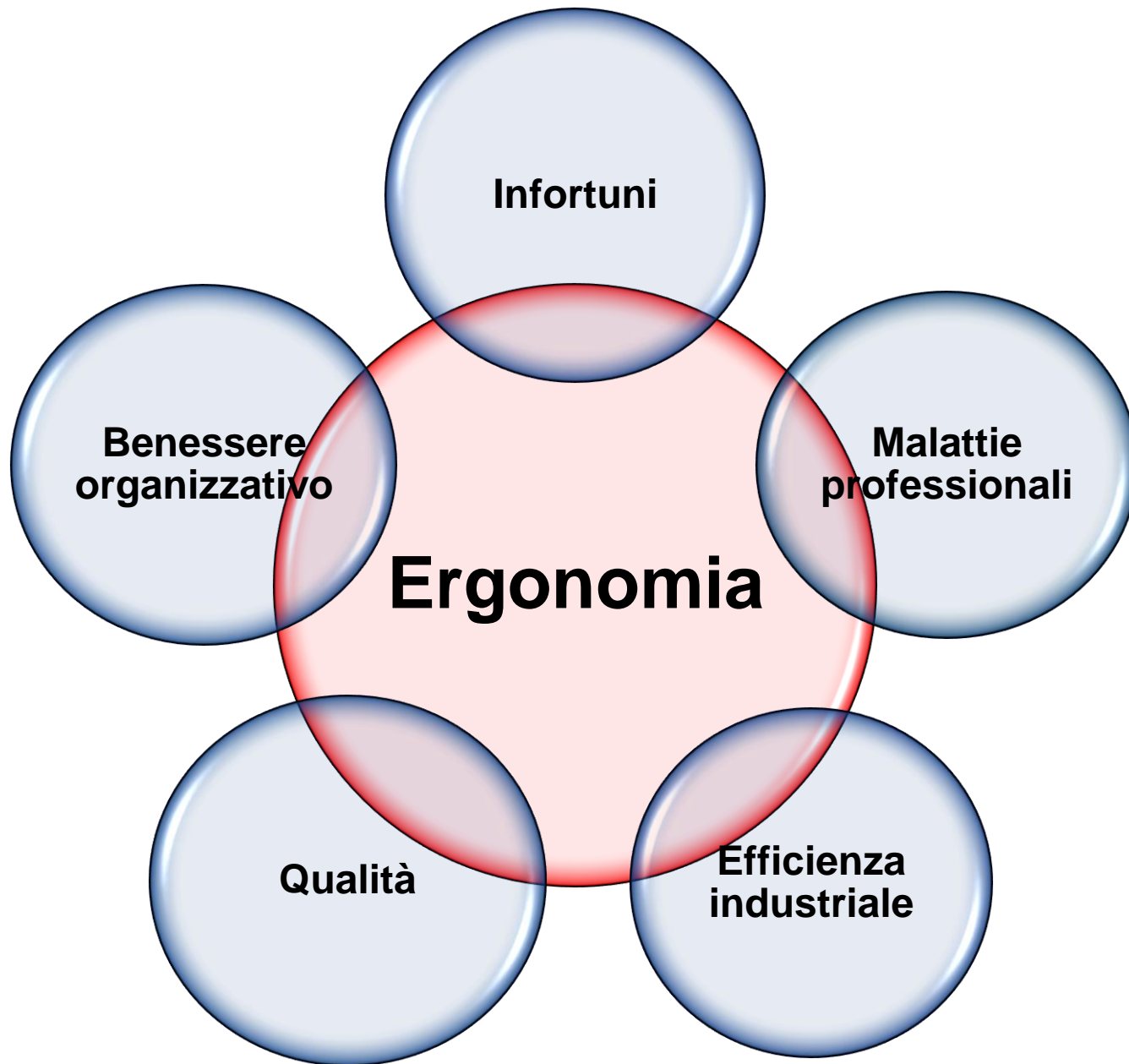

Grazie per l'attenzione

”In ogni iniziativa industriale non c'è valore del successo economico se non c'è anche l'impegno nel progresso sociale.”

(Aristide Merloni, 1967)

